



LadyBug Technologies, LLC

LB5918L

True-RMS Power Sensor

LB5918L



LB5918L Data Sheet



Key PowerSensor+™ Specifications

- Frequency Range: 9 kHz to 18 GHz
- Dynamic Range: -60 dBm to +26 dBm
- < 1.1:1 Typical VSWR
- 1.3% Typical total RSS error @15 GHz
(See example on page 13 of this document)
- RMS Responding & modulation independent
- Command Compatible with U2000
- Thermally Stable
- No User Zero required before use
- Compatible with Windows, LINUX & More
- Full dynamic range processed with each sample

Key Features

- Standard connector: High quality Type-N male
- Connector options to assure the best match
- Includes full featured software
- Interactive IO Software aids ATE development
- Persona feature allows competitive instrument compatibility
- Support for Windows, LINUX, & embedded systems
- Interfaces: USBTMC and USBHID
- Interface (Optional): SPI or I2C direct connectivity + USB
- Industry compatible IEEE 488.2 SCPI Command Set
- Includes robust driver support and example code
- Measurement storage: 50 million measurements
- User settable real-time clock with internal backup
- Security options - MIL and SEC

LB5918L

LB5918L can be ordered with options including the LB956A ATE Mounting Bracket, Option A05 Secure USB cable, Option SPI (SPI & I2C Interface with Cable). Consult the LB5900 series sensor ordering guide.



LB956A ATE
Mounting Bracket
(Also shown with SPI Cable)



Secure
USB Cable



Optional
Connectors
Available

LB5918L

General Description

The LB5918L is a high accuracy True-RMS Power Sensor for general purpose use. The sensor utilizes a highly accurate, thermally stabilized, two path, RMS responding, square law diode detection scheme. The sensor makes accurate measurements on any signal regardless of its modulation bandwidth.

The sensor's patented thermally stable technology means that measurements do not drift and user zeroing & calibration before use are eliminated. Measurement interruption due to automatic calibration is also eliminated bolstering the performance and reliability of ATE systems. Unlike competitive sensors, it is never necessary to disconnect the source to zero your LB5900 series sensor.

LadyBug's PMA-12 Power Meter Software is included. The sensor is useful for research & development, manufacturing & service applications including radar, satellite, telecommunications, 802.11... testing, etc.

The sensor features the industry's most complete set of options for programmatic access and embedded applications. USB HID and USBTMC interfaces offer platform independent connectivity to most computers. The sensor utilizes standard SCPI commands and is compatible with competitive VISA IO libraries. Additionally, the sensors Persona capability allows emulation and compatibility with various VNA's, Spectrum Analyzers, Sources and ATE systems written for other sensors.

The sensor includes a rich set of triggering capabilities such as level controlled internal triggering, external triggering, delays, hold off and more.

Option SPI, SPI & I2C interfaces can be used for embedded applications, microprocessors and FPGA's;

Optional UOP, Unattended Operation can be set up and data collected through the sensors USB or SPI/I2C ports. Once measurements are set up, a computer or power meter is not required to operate the sensor making it ideal for unattended applications. A high accuracy real time clock included.

Optional Recorder (calibrated analog output) for leveling and control applications. If Option UOP has been purchased, Recorder Out can be used with no computer attached.

Option MIL prevents the sensor from accepting any writes to non-volatile memory assuring data security.

Option SEC, Secure Erase allows the user to erase all user set non-volatile memory including customer calibration, presets, offsets, FDO's (Frequency dependent offset) and UOP memory.

LB5918L

LB5900 series sensors use PMA-12 Precision Power Meter software. The software allows users to make a wide variety of measurements from basic average power measurements to complex triggered measurements. Refer to the PMA-12 user's manual for further information.

In addition to PMA-12, LadyBug provides an interactive IO utility with source code, a Persona utility, plus a variety of programmatic code and support.

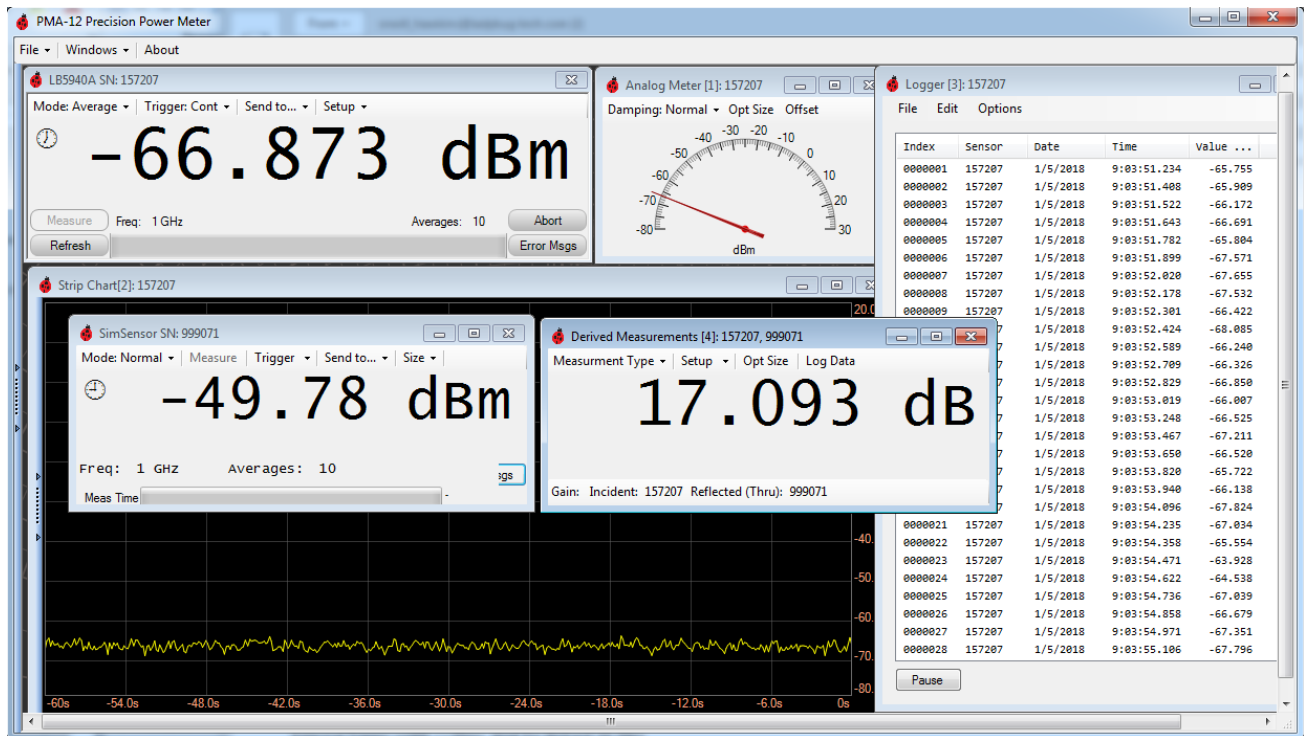

PMA-12 Precision Power Meter features include

- For use with any LB5900 Series Sensor.
- All sensor features are included with no software registration requirement or fees.
- The software can be used as many computers as required without additional charge.
- Two sensor calculation window with calculations for Gain, Loss VSWR, Reflection Coefficient, Mismatch Loss, Return Loss.
- USB threading increases performance when using multiple sensors.
- Triggering control including setting Level, Delay, Slope, Hysteresis, Impedance, more.
- Tabular logging with file storage and retrieval.
- Strip Chart including scaling, pause, store, recall etc.
- Attractive Analog Gauge with damping control and sizing.
- Unattended Operation control.
- Recorder Out (analog out) control for scaling etc.
- Offset controls including simple offset and frequency dependent offset tables.
- Default and User Presets

LB5918L

Parameter	Specification	
Connector	Type-N Male	
Frequency Range	9 kHz to 18 GHz	
Dynamic Range (Calibrated Measurement Range)	-60 dBm to +26 dBm	
Maximum Power Level		
Continuous average power	+26 dBm (400 mW)	Damage Level: +29 dBm (800 mW)
Peak pulse power ¹	+33 dBm (2 W)	Damage Level: +36 dBm (4 W)
Maximum energy per pulse ¹	20 W-us	Damage Level: 40 W-us
Maximum DC input voltage	10 VDC (On the RF Input)	
Recommended Calibration Cycle	1 year	

Note 1: Pulse repetition must respect average power over anyone pulse duty cycle, regardless of varying duty cycle.

Accuracy (Total RSS Unc = $\sqrt{(Mm^2+CF^2+L^2+N^2+T^2+Z^2)}$)

Mm (Mismatch); CF (Cal Factor); N (Noise); L (Linearity); T (Temperature); Z (Zero Offset). All uncertainty terms are converted to percentages for RSS calculation. 2 Use the following formula to determine Zero Offset uncertainty (%): $Z = (\text{Zero Offset Power} / \text{Measured Power}) * 100$. 3 Linearity and Zero Offset are measured as a combined specification as LadyBug sensors require no meter zeroing or reference calibration before use. Please refer to *Initial Stabilization Time* section for additional details.

Parameter	Specification	Typical
Match (Type-N)		
9 kHz to 15 kHz	1.45 VSWR	1.25 VSWR
15 kHz to 40 kHz	1.25 VSWR	1.11 VSWR
40 kHz to 2 GHz	1.13 VSWR	1.05 VSWR
2 GHz to 8 GHz	1.18 VSWR	1.07 VSWR
8 GHz to 15 GHz	1.23 VSWR	1.09 VSWR
15 GHz to 18 GHz	1.29 VSWR	1.1 VSWR

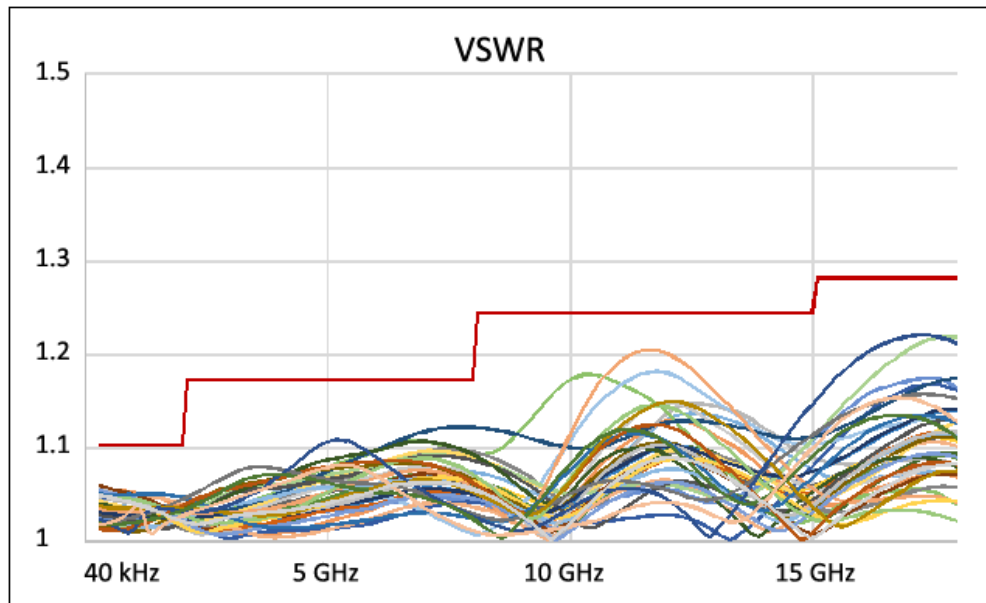

Match (VSWR) Specification Maximum (red line)
Typical Production Test Data

LB5918L

Parameter	Specification	Typical
Calibration Factor Unc (Type-N Male)	K=2 (K is coverage factor)	K=1
9 kHz to 40 kHz	2.88%	1.44%
40 kHz to 2 GHz	2.23%	1.12%
2 GHz to 10 GHz	2.45%	1.23%
10 GHz to 18 GHz	2.85%	1.43%
Linearity Unc		
+10 dBm to +20 dBm	3.0%	1.0%
-10 dBm to +10 dBm	2.0%	0.5%
-20 dBm to -10 dBm	3.5%	1.5%
-60 dBm to -20 dBm	2.0%	0.5%
Noise @ Power Range ^{1,2}		
-40 dBm to +26 dBm ³	0.35%	0.025% to 0.15% ⁴
-60 dBm to -40 dBm	0.5nW ⁵	0.2nW ⁶

Noise notes:

- Noise is two times the standard deviation of 100 measurement points
- Number of Averages for each measurement rate
Normal 16; Double 32; Super 384
- For Normal measurement rate, when averages above 16 and power is above -40 dBm noise error is insignificant
- Varies with power level
- Noise is determined by multiplying the value by 4/sqrt(Normal measurement rate averages)
Example 1(Specification): For 1024 Averages noise is less than $0.5nW * (4/\sqrt{1024}) = 0.063nW$
Example 2(Specification): For 128 Averages noise is less than $0.5nW * (4/\sqrt{128}) = 0.18nW$
- Noise is determined by multiplying the value by 4/sqrt(Normal measurement rate averages)
Example 1(Typical): For 1024 Averages noise is less than $0.2nW * (4/\sqrt{1024}) = 0.025nW$
Example 2(Typical): For 128 Averages noise is less than $0.2nW * (4/\sqrt{128}) = 0.071nW$

Parameter	Specification	Typical
Zero Offset ^{1,2}	$\{[(1.0nW @ 25^{\circ}C) + \Delta T \times (0.075nW/^{\circ}C)] \pm 0.01nW /month\}$	$\{[(0.5nW @ 25^{\circ}C) + \Delta T \times (0.0375nW/^{\circ}C)] \pm 0.005nW /month\}$

Zero Offset Notes

- Use the following formula to determine Zero Offset uncertainty (%): $Z = (Zero\ Offset\ Power / Measured\ Power) * 100$.
- Linearity and Zero Offset are measured as a combined specification as LadyBug sensors require no meter zeroing or reference calibration before use.

LB5918L

Parameter	Specification	Typical
Temperature Unc		
40°C - 55°C	2.5%	0.5%
30°C - 40°C	0.5%	0%
20°C - 30°C	0%	0%
10°C - 20°C	0.5%	0%
0°C - 10°C	2.5%	0.5%

Thermal Stability

LadyBug's patented thermal stability technology is utilized in the LB5918L sensor. Measurements remain stable over the entire operating temperature range. No user intervention, zeroing or calibration is required. This patented process also defines the zero-power conditions and eliminates zeroing requirements. Measurements are not interrupted for zeroing or calibration.

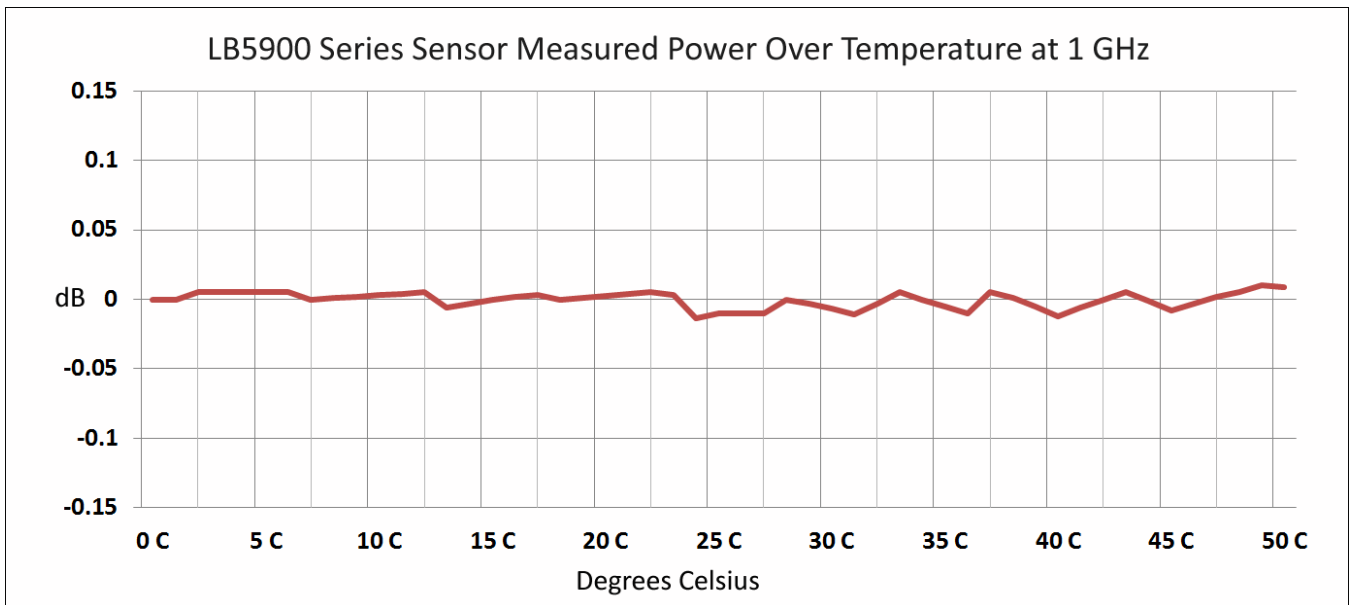

Average Detector Mode Measurement Rate (MRAT)

Setting ->	Normal	Double	Fast	Super
Samples per measurement	384	192	32	16
Number of Averages per Measurement	1 to 1024	1 to 1024	1	1 to 4069
Measurement time per Average	38.4ms	19.2ms	3.2ms	1.6ms

LB5918L

Settling time in seconds for Average Detector Mode; 30dB decreasing power step

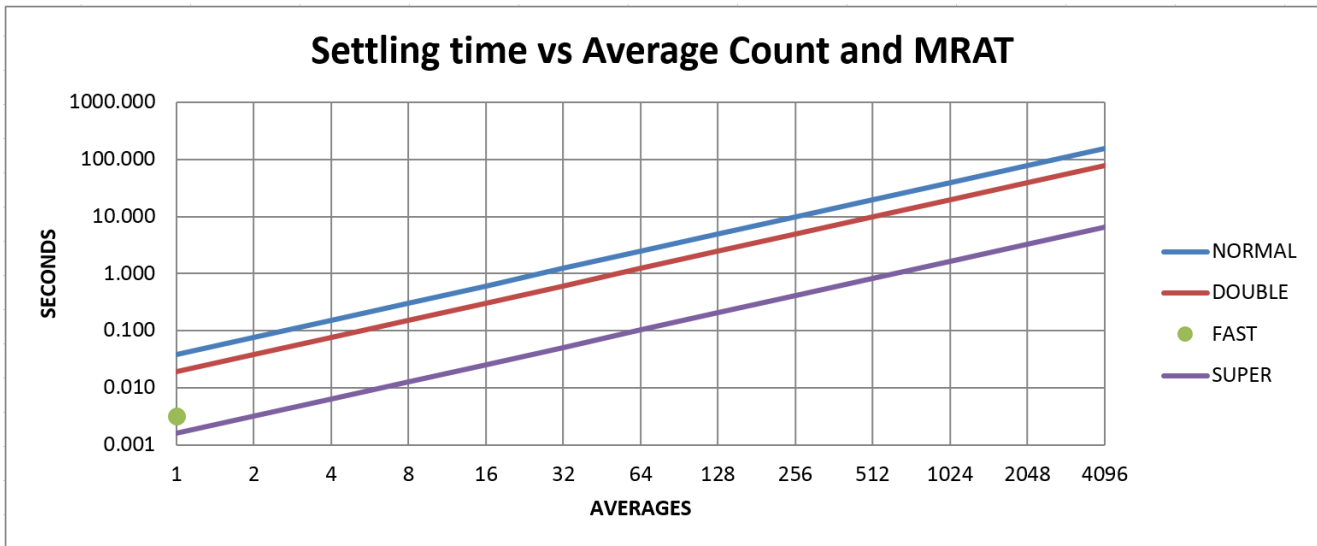

Interface Connectivity

LB5900 series sensors support both USBTMC and USB HID. Direct control of the sensor is also possible using optional SPI and I2C interface ports. These connectivity functions are optimized for programmatic control as well as unattended and logged power measurements. The sensors can be setup, controlled and data taken from any of the connectivity options. LadyBug sensors are provided with a full featured application that utilizes the sensors USB interfaces. Refer to the Option SPI documentation for information regarding I2C and SPI interfaces.

USBTMC	USB488 compliant
USB HID	USB Human Interface Device Class compliant
SPI / I2C (Option SPI)	Cable and connector are included with option SPI. Cable may also be used to power the sensor for unattended applications.

Remote Programming

The sensor is designed for full programmatic control in ATE systems and other applications requiring remote programming. LB5900 Series sensors use SCPI (Standard Commands for Programmable Instruments) commands. The sensor's three connectivity options use the SCPI command set. LadyBug's SICL test harness can be utilized for testing and developing automated test systems. Refer to the appropriate programming guide for additional information on remote programming.

Supporting Ports	USBTMC, USB HID, SPI/I2C
Command Set	SCPI (Standard Commands for Programmable Instruments)
Compatibility	Compatible with systems using USBTMC programmatic control, NI™ & Agilent™ Visa IO libraries, Agilent™ U2000 & others using SCPI command set.*

* Agilent is a trademark of Agilent Technologies Inc; NI is a trademark of National Instruments, Inc.

LB5918L

Analog Recorder Output

Option 001, Analog Recorder Out. Recorder Output is a filtered analog output that can be used for various purposes. The output provides an accurate scaled voltage representing power level of the signal. The output is linear (not log dB) and can be scaled. When enabled, Recorder Out uses the same SMB port used by Trigger Out making the port unavailable for triggering use. Trigger in is not affected.

Output filter bandwidth	Average Detector mode: 0.001 Hz to 32 Hz (settable) Normal Detector mode: 0.001 Hz to 81 Hz (settable)
Output range	0 to 1 Volt into 1,000 Ohms. Note: Potential of 2.5 Volts when set as Recorder Out; or 5 Volts when used as Trigger Output
Output impedance	1 k Ohms
Resolution	+/- 25 μ V
DC Offset	0 to 5 mV
Scale	Linear
Connector	SMB Male (shared with Trigger Out and Wideband Video Out)

Triggering

LB5900 Series Sensors' trigger functions including slope, level, trigger delay, hold off and rearm delay can be set. External trigger Input and are available for gated measurements, synchronizing multiple sensors, or other purposes. Trigger Input and output use SMB Male connectors, these may be shared with other options.

General	
Trigger source	Internal (signal level), Immediate, External.
Trigger Delay range	+/- 10 Seconds
Auto trigger delay	Varies based on resolution setting (Default 45 ms). Average Mode: 11 ms to 61 ms.
Resolution	1 μ s
Trigger Out pulse width	500 ns
Trigger Out level	Maximum \approx VUSB \approx 5.5VDC (typical). Typical high level 4.0V with 600 ohm load (With VUSB=5.0V). Max low level 0.8 V. Minimum load resistance 200 ohms.
Internal Triggering	
Level	Settable to approximately -50dBm to 20dBm
Level resolution	0.1 dB
Slope	Positive or Negative
Hysteresis	Settable to 0 dB to 3 dB
External Triggering	
Trigger input	Min high level 2.0 Volts, Max low level 0.8 Volts.
Input load	Selectable 100 k Ω or 50 Ω
Timing requirements	Minimum pulse: Width 25 ns (on), 25 ns (off); Repetition: 50 ns (min)
Absolute input limits	+5.5 Volts maximum; -0.5 Volts minimum

LB5918L

Option MIL

Option MIL is designed to address security and data sanitization issues. When purchased with this option, the user cannot write to any non-volatile memory. Consult the factory for additional information regarding option MIL.

Sanitization Option (SEC)

The sanitization option adds secure erase capability. When the SEC command is executed, all non-volatile memory is erased including User Presets, Persona information, Store & Recall data, User Cal, Simple offsets and FDO tables. The process is an *erase - random overwrite - erase* process. For additional security users can execute the command repeatedly. The option is not available if Option MIL is purchased because non-volatile memory writes are disallowed with the option.

Store, Recall and Logging Memory

The LB5918L contains volatile and non-volatile memory.

Store & recall functions for the sensor's state and register functions such as Frequency, Averages and Analog Recorder Out settings have a lifetime of 1 million write and erase cycles.

When Option UOP is present, the sensor contains separate, non-volatile flash memory that is designed for long term logging of measurements.

Note: If option MIL (security) is ordered, non-volatile flash memory is not accessible. This includes all state and register functions such as Frequency, Averages, Analog Recorder Out etc.

Parameter	Specification
Non-volatile NAND flash	50 Million measurements
Maximum storage rate	1000 measurements per second

Unattended Operation (UOP)

Unattended operation is used to make autonomous measurements. Once setup using a computer, the sensor only requires power to function. Measurements are stored in the sensors non-volatile memory and are time stamped using the sensor's internal real time clock. The option allows the use of trigger functions. Recorder output can be enabled while in unattended operation allowing calibrated analog output functions with no computer or power meter connected. Power can be applied using a USB power only cable or if Option SPI has been purchased, its ribbon cable can be used to apply power. Measurement storage using UOP is not possible when Option MIL is installed.

LB5918L

Real time clock

If Option UOP is present, the LB5900 Series Sensors contains a real time clock that is used to time stamp logged measurements. When the sensor is powered on, the sensors high accuracy time base is used to increase the accuracy of the real time clock.

Time accuracy	Typical: Un-powered 20 ppm at 25 degrees Celsius; Under power & stable, 2 ppm (disciplined by high accuracy time-base). Consult the factory for further information.
Functionality	Provides time stamp data for measurements stored in memory. When used with Option UOC (unattended operation), can deactivate low power mode, trigger measurements and activate low power mode
Backup	Super cap. When fully charged, provides 1 day (typical) RTC operation with no power applied to the sensor. Minimum charge time 5 minutes.

Environmental	Operating	Storage
Temperature	0°C to 55°C	-25°C to 85°C
Humidity	15% - 95% non-condensing	15% - 95% non-condensing
Altitude	10,000 feet (3,000 meters)	50,000 feet (15,000 meters)

Initial Stabilization Time

For general use, LB5900 series sensors are stable 5 minutes after electrical power is applied. Specifications detailed in this datasheet are valid ONLY after a 30 minute warm up period and for continuous wave (CW) signals unless otherwise stated. The recommended calibration interval for this product is one year. Specifications apply over the listed temperature and relative humidity range unless otherwise stated.

LB5918L

Uncertainty Calculation Work Sheet

Use this sheet to calculate uncertainty for a specific set of conditions using the root sum of squares method.

Conditions

Operating Frequency (GHz)	
Power Level (dBm)	
DUT Match (VSWR)	
Temperature (°C)	

Sensor characteristics at conditions

Cal Factor (% & Actual)		
Linearity (% & Actual)		
Noise (% & Actual)		
Uncertainty Due To Temperature (% & Actual)		
Match (VSWR)		
Zero Offset		

1. Calculate Sensor reflection coefficient, ρ from Sensor VSWR

$$\rho_{\text{sens}} = (\text{VSWR}-1)/(\text{VSWR}+1)$$

$$\rho_{\text{sens}} =$$

2. Calculate DUT reflection coefficient, ρ from DUT VSWR

$$\rho_{\text{DUT}} = (\text{VSWR}-1)/(\text{VSWR}+1)$$

$$\rho_{\text{DUT}} =$$

Note: Reflection coefficient can be calculated from return loss using the formula $\rho=10^{(-\text{RL}/20)}$

3. Calculate total match uncertainty

$$\text{Mm} = (1+(\rho_{\text{sens}} * \rho_{\text{DUT}}))^2-1$$

$$\text{Mm} =$$

4. Calculate Zero Offset uncertainty (See Specification and notations)

- a. Convert power from dBm to Linear

$$\text{Linear Power} = 10^{(\text{PowdBm}/10)}$$

$$\text{Linear Power} =$$

- b. Calculate Zero Offset

$$\text{Zero Offset} = (\text{Zero Offset Specification}/\text{Linear Power})$$

$$\text{Zero Offset} =$$

5. Calculate Total RSS uncertainty

$$\text{Uncertainty (\%)} = \sqrt{(\text{Mm}^2 + \text{CF}^2 + \text{L}^2 + \text{N}^2 + \text{T}^2 + \text{Z}^2)} * 100$$

$$\text{Uncertainty (\%)} =$$

LB5918L

Uncertainty Calculation Work Sheet Example

This sheet was completed using typical sensor data.

Conditions

Operating Frequency (GHz)	15
Power Level (dBm)	-20
DUT Match (VSWR)	1.20
Temperature (°C)	25

Sensor characteristics at conditions

Cal Factor (% & Actual)	1.71%	0.0171
Linearity (% & Actual)	0.5%	0.005
Noise (% & Actual)	0.15%	0.0015
Uncertainty Due To Temperature (% & Actual)	0%	0.0
Match (VSWR)		1.09:1
Zero Offset		3.5E-10

1. Calculate Sensor reflection coefficient, ρ from Sensor VSWR

$$\rho_{\text{sens}} = (\text{VSWR}-1)/(\text{VSWR}+1)$$

$$\rho_{\text{sens}} = (1.09-1)/(1.09+1) = 0.043$$

2. Calculate DUT reflection coefficient, ρ from DUT VSWR

$$\rho_{\text{DUT}} = (\text{VSWR}-1)/(\text{VSWR}+1)$$

$$\rho_{\text{DUT}} = (1.2-1)/(1.2+1) = 0.091$$

Note: Reflection coefficient can be calculated from return loss using the formula $\rho=10^{(-RL/20)}$

3. Calculate total match uncertainty

$$Mm = (1+(\rho_{\text{sens}} * \rho_{\text{DUT}}))^2-1$$

$$Mm = (1+(0.043*0.091))^2-1 = 0.0078$$

4. Calculate Zero Offset uncertainty (See Specification and notations)

- a. Convert power from dBm to Linear

$$\text{Linear Power} = 10^{(\text{PowdBm}/10)}$$

$$\text{Linear Power} = 10^{(-20/10)} = .01\text{mw}$$

- b. Calculate Zero Offset

$$\text{Zero Offset} = (\text{Zero Offset Specification}/\text{Linear Power})$$

$$\text{Zero Offset} = (0.35\text{nw} / .01\text{mw}) = .000035$$

5. Calculate Total RSS uncertainty

6. Uncertainty (%) = $\sqrt{(Mm^2+CF^2+L^2+N^2+T^2+Z^2)} * 100$

$$\text{Uncertainty (\%)} = \sqrt{(0.0078^2+0.0089^2+.005^2+.0015^2 +0.0^2+.0000350^2)} = 0.0130 = 1.3\%$$

LB5918L

LB59XXX Outline drawings

Dimension tolerance +/- 0.063"

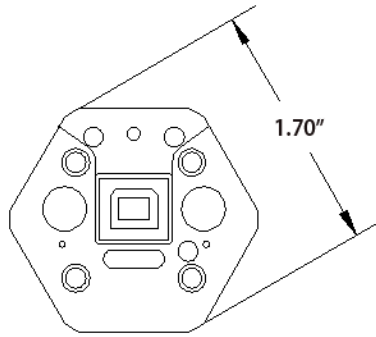

Rear (USB) View

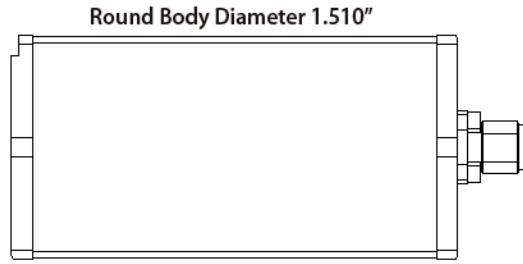

Side View

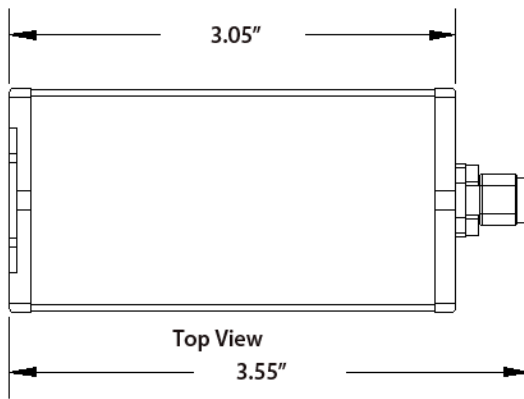

Top View

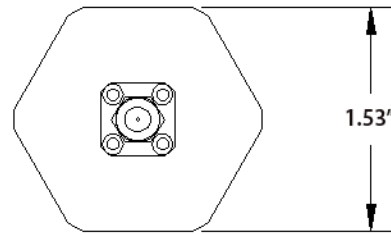

Front View

SMA & 3.5mm Connectors

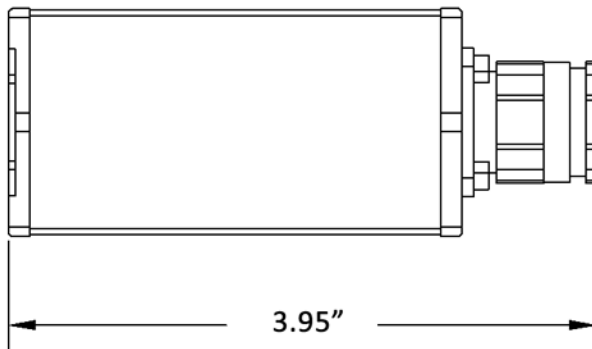

3.95"

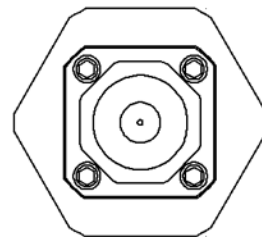

Type-N Male Connector